

EFL302X4

Li-Ion Counterbalance Forklift 3000kg with manual-swap battery packs



EP
Let's grow together

- Powered by innovative lightweight manual-swap, modular lithium battery packs
- Manual-swap battery packs enable operations where charging possibilities are limited
- Portable battery design creates opportunities for rental business
- Modular battery pack design allows adding modules for maximum endurance flexibility
- Advanced power system integrates lithium, smart BMS, and PMS motor
- Optional charging station streamlines management of multiple battery packs
- Robust and water-proof design adapts to diverse environments
- Wide mast and spacious cabin improve operator comfort and safety



Manufacturer				EP
Model designation				EFL302X4
Drive				Electric
Load capacity	Q	kg		3000
Load center distance	c	mm		500
Service weight		kg		4354
Retracted mast height	h1	mm		2070
Lift height	h3	mm		3000
Height, mast extended	h4	mm		4096
Length to face of forks	l2	mm		2665
Overall width	b1/b2	mm		1228
Fork dimensions	s/e/l	mm		45/122/1070
Turning radius	Wa	mm		2428
Travel speed, laden/unladen		km/h		11/12
Lifting speed, laden/unladen		m/s		0.29/0.36
Lowering speed, laden/unladen		m/s		0.4/0.4
Max. gradeability, laden/unladen		%		15/15
Drive motor rating S2 60 min		kW		8
Battery voltage/nominal capacity		V/Ah		80V/100Ah

▣ Features

■ Innovative Lightweight, Manual-swap Batteries

The EFL302X4 introduces a revolutionary approach to battery management with its lightweight, manual-swap battery packs. Each battery module can be easily handled by operators without specialized equipment, enhancing operational flexibility. The specially designed side door provides a quick access to the battery compartment, streamlining the swapping process and minimizing downtime. The standard compact battery pack also provides convenience for maintenance and repair thanks to easy handle and few spare parts needed.



■ Remote battery charging

X4 is the perfect truck on off-grid applications like agriculture or construction sites. As the batteries can be removed transported and charged elsewhere while the truck remains on remote job site. This feature allow safety increase as truck cannot easily be moved and stolen.



■ Optional Multi-Battery Charging Station

Complementing the EFL302X4's innovative battery system is an optional charging station designed specifically for this model and it's a plug-and-play solution. This compact modular charging station can charge the batteries outside of the forklift and can accommodate charge up to six batteries simultaneously. Thanks to this charging helper, there is no constraints or limitation even in the environments without charging facilities or with high safety requirements. This feature enhances the efficiency and safety of battery management and ensures a constant supply of ready-to-use power packs.

Additionally, its ergonomic design allows for optimal operating height, enabling easy handling of batteries during the charging process.



**PLUG-AND-PLAY SOLUTION:
MODULAR BATTERY PACKS CHARGING STATION**

■ Extend Runtime and Future Flexibility to the Maximum

The EFL302X4's innovative battery system, featuring six swappable packs divided into two sets of three, enables extended work cycles with minimal downtime. When power runs low, three batteries can be easily removed for charging while the forklift continues to operate on the remaining three, ensuring maximum uptime and productivity in demanding environments.

The EFL302X4's battery system can also grow with customers' business. While the standard configuration includes a set of three battery packs, the option to expand to six packs or more unlocks the forklift's full operational potential. This scalability ensures that the EFL302X4 can meet growing demands and maximize capabilities as needed.



■ Profitability with Flexible Business Modes

With the lightweight battery packs and the optional charging station, the EFL302X4 opens up new possibilities in forklift operations and ownership. The portability of these batteries creates a unique opportunity to treat batteries as a mobile, rentable commodity. For example, a battery rental service could be established, where fully charged packs are distributed to multiple sites or customers as needed. Businesses can now consider options like pay-per-use or subscription-based services, potentially reducing upfront costs and offering more flexible power solutions tailored to varying operational demands.



■ Advanced Power System: Lithium Technology, Smart Management, and PMS Motor

The EFL302X4 integrates advanced power technologies for reliable performance and efficiency. Standard 80V/100Ah lithium battery (one set of three packs) features high energy density and extended cycle life, which is complemented by a smart Battery Management System (BMS) that optimizes battery performance and longevity. Powering the forklift is a Permanent Magnet Synchronous (PMS) motor, known for its high energy conversion efficiency.

This trio of technologies enables the EFL302X4 to operate efficiently, featuring reduced charging times, lower maintenance needs, and significantly reduced energy consumption.

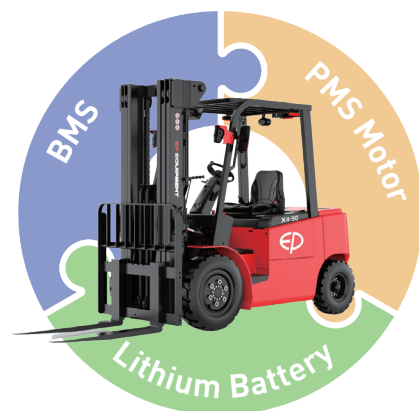

■ Improved components for easy, safe and comfortable operation

The EFL302X4 series is equipped with improved components such as the new mast with high visibility, the new seat with armrest, the new LED front lights, the wider brake pedal and the large LED display.



Li-ion Counterbalance Forklift 300kg

EFL302X4

Distinguishing mark	1.1	Manufacturer			EP
	1.2	Model designation			EFL302X4
	1.3	Drive			Electric
	1.4	Operator type			Seated
	1.5	Load capacity	Q	kg	3000
	1.6	Load center distance	c	mm	500
	1.8	Load distance, centre of drive axle to fork	x	mm	486
	1.9	Wheelbase	y	mm	1760
	Service weight	2.1	Service weight		kg
2.2		Axle loading, laden front/rear		kg	6537/817
2.3		Axle loading, unladen front/rear		kg	1854/2696
Tyres/chassis	3.1	Tyre type			Pneumatic
	3.2	Tyre size, front			28X9-15-14PR
	3.3	Tyre size, rear			6.5F-10-10PR
	3.5	Wheels, number front/rear (x=drive wheels)		mm	2X/2
	3.6	Tread width, front	b10	mm	989
	3.7	Tread width, rear	b11	mm	980
Dimensions	4.1	Tilt of mast/fork carriage forward/backward	α/β	°	6/10
	4.2	Retracted mast height	h1	mm	2070
	4.3	Free lift	h2	mm	130
	4.4	Lift height	h3	mm	3000
	4.5	Height, mast extended	h4	mm	3725
	4.7	Height of overhead guard (cabin)	h6	mm	2143
	4.8	Seat height/standing height	h7	mm	1141
	4.12	Tow coupling height	h10	mm	468
	4.19	Overall length	l1	mm	3735
	4.20	Length to face of forks	l2	mm	2665
	4.21	Overall width	b1/b2	mm	1228
	4.22	Fork dimensions	s/e/l	mm	45×122×1070
	4.23	A,B Fork carriage class/type A, B			3A
	4.24	Fork carriage width	b3	mm	1100
	4.31	Ground clearance, laden, below mast	m1	mm	125
	4.32	Ground clearance, center of wheelbase	m2	mm	137
	4.34.1	Aisle width for pallets 1000×1200 crossways	Ast	mm	4115
4.34.2	Aisle width for pallets 800×1200 lengthways	Ast	mm	4315	
4.35	Turning radius	Wa	mm	2428	
Performance data	5.1	Travel speed, laden/unladen		km/h	11/12
	5.2	Lifting speed, laden/unladen		m/s	0.29/0.36
	5.3	Lowering speed, laden/unladen		m/s	0.4/0.4
	5.8	Max. gradeability, laden/unladen		%	15/15
	5.10	Service brake			Hydraulic
	5.11	Parking brake			Mechanical
Electric-engine	6.1	Drive motor rating S2 60 min		kW	8
	6.2	Lift motor rating at S3 15%		kW	16
	6.4	Battery voltage/nominal capacity		V/Ah	80V/100Ah
	6.5	Battery weight		kg	73.5
Addition data	8.1	Type of drive control			PMSM
	10.5	Steering design			Hydraulic
	10.7	Sound pressure level at the driver's ear		dB(A)	60

If there are improvements of technical parameters or configurations, no further notice will be given.
The diagram shown may contain non-standard configurations.

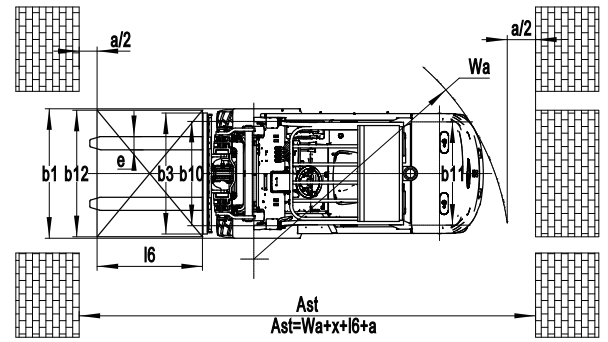
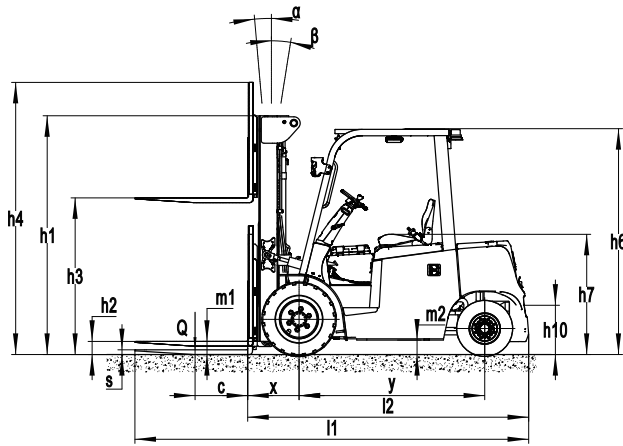

Mast Option

Mast types	Lift height (h3)	Height, Mast			Height, Free lift(h2)	
		Height, mast lowered(h1)	Height, mast extended(h4)		No shelving	With shelving
			No shelving	With shelving		
	mm	mm	mm	mm	mm	mm
2-Standard Mast	2700	1910	3425	3830	130	130
	3000	2070	3725	4130	130	130
	3300	2210	4025	4430	130	130
	3500	2310	4225	4630	130	130
	3600	2360	4325	4730	130	130
	4000	2610	4725	5130	130	130
	4300	2760	5025	5430	130	130
	4500	2860	5225	5630	130	130
2-Free Mast	3000	2040	3770	4175	1350	945
	3300	2190	4070	4475	1500	1095
	3600	2340	4370	4775	1650	1245
3-Free Mast	4300	2080	5030	5435	1390	985
	4500	2160	5270	5675	1470	1065
	4800	2265	5530	5935	1575	1170
	5000	2350	5720	6125	1660	1255
	5500	2600	6220	6625	1910	1505
	6000	2850	6720	7125	2160	1755

Option

Optional items	EFL302X4
Fork dimension	○122*40*920●122*40*1070○122*40*1150○122*40*1220○122*40*1370 ○122*40*1500○122*40*1600○122*40*1700○122*40*1820○122*40*1900 ○122*40*2000○122*40*2200
Front wheel material	○Pneumatic○Solid○Non-marking
Rear wheel material	○Pneumatic○Solid○Non-marking
Battery capacity	○80V100AH○80V200AH
Charger	○80V65A (for 100AH battery)○80V100A (for 200AH battery)
Charging station	○Charging station (6 charging slots, 24V/50A each)
Battery indicator	●With hourmeter (Bluetooth) without PSE
Seat type	○Comfortable with safety belt switch ○Seat with armrest with safety belt switch
Attachments	○Built-in sideshifter○External shifter○Fork positioner with sideshift
Traction pin	●Yes and not customized
Anti-static chain	●Yes and not customized
Front lamp	●LED
Rear lamp	●No○LED
Warning lamp	●Yes and not customized
Turn signal light	●LED
Blue lamp	●No○Rear○Front and rear
Area warning lamp	●No○Both sides○Both sides and rear
Rearview mirror	●One in front○Two on sides and one in front
Buzzer	●Yes and not customized
OPS system	●Yes and not customized
USB interface	●Yes and not customized
Telematics	●Yes and not customized○No
Turn speed control	●No
Heating system for lithium battery charging	●No○Yes and not customized
Operator identification device	●No○Card reader device
Hydraulic control	●Mechanical lever
Rear armrest horn	●No○Yes and not customized
Cabin	●No
Overhead guard	●No○With tempered glass
Note: ●Standard ○ Optional - Inconformity	